



Project Name: _____

Location: _____

Item #: _____ Qty: _____

Model: _____

INTELLIGENT SERIES 22" MODULAR ICE MACHINES

MODEL: MIM360N MIM360NH



Maxx Ice Intelligent Series modular, air-cooled ice machines are designed for high volume ice production application. The modular units are compatible with most ice storage bins and beverage dispensers. Available in both full or half dice cubes, the stainless steel and black trim exterior features a hinged front panel for easy cleaning and servicing. The digital controls, vertical evaporator and proven ice making technology will deliver years of reliable ice production.

FEATURES AND CONSTRUCTION

- Stainless steel, black trim exterior
- Narrow 22" width - fits in tight places where space and height is limited
- Air-cooled compressor
- Programmable, user-friendly digital controls
- Digital screen displays ice machine status
- Automatic cleaning cycle and bin overflow prevention
- Power for unit also illuminates the internal LED light in storage bin (MIB310N - sold separately)
- Hinged front panel for easy cleaning and service
- Units are stackable for increased ice production (optional adapter is required)

DAILY ICE PRODUCTION

Air Temp 70°F (21°C) / Water Temp 50°F (10°C)

MIM360N..... 373 lbs (169 kg)

MIM360NH 361 lbs (164 kg)

Air Temp 90°F (32°C) / Water Temp 70°F (21°C)

MIM360N..... 288 lbs (131 kg)

MIM360NH 285 lbs (129 kg)

OPERATING REQUIREMENTS

Ambient Air Temperature Range..... 50° to 100°F (10° to 38°C)

Water Temperature Range 41° to 90°F (5° to 32°C)

Water Usage per 100 lbs of ice..... 13.12 Gallons (49.7L)

Water Supply Line Connection 3/8" FPT

Water Pressure Range:

Min PSI..... 15 Max PSI 80*

Min Bar 1.0 Max Bar..... 5.5

*Above 80 PSI requires a regulator

Energy Consumption per 100 lbs of ice:

MIM360N/NH 6.1 kWh/100 lbs



Designed to fit perfectly with the MIB310N Bin (sold separately)

ELECTRIC

115V / 60Hz / 1Ph
(230V / 50-60Hz / 1Ph is available as an option)
6' (2m) NEMA 5-15P cord set included

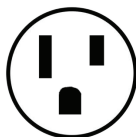

NEMA 5-15P

3RD PARTY APPROVALS



Certified to ANSI NSF 12



Certified to ANSI UL 563



DOE 2018 Compliant



Meets Energy Star Guidelines

MAXX ICE WARRANTY (USA / CANADA)

Contact Maxx Ice for warranty statement at
TechnicalServices@TheLegacyCompanies.com or 877.368.2797



MAXX ICE

INTELLIGENT SERIES 22" MODULAR ICE MACHINES

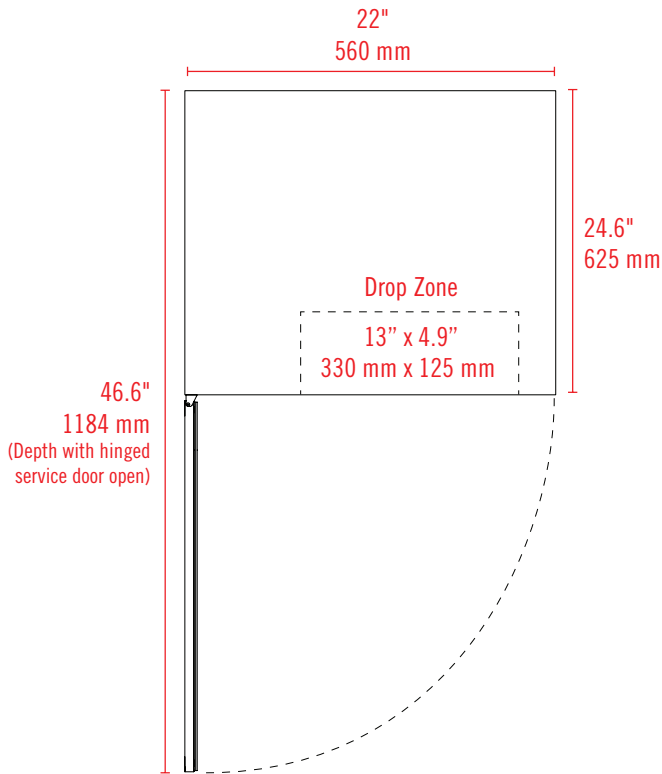
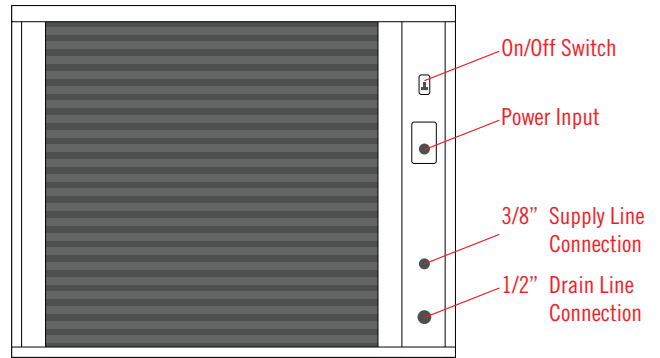
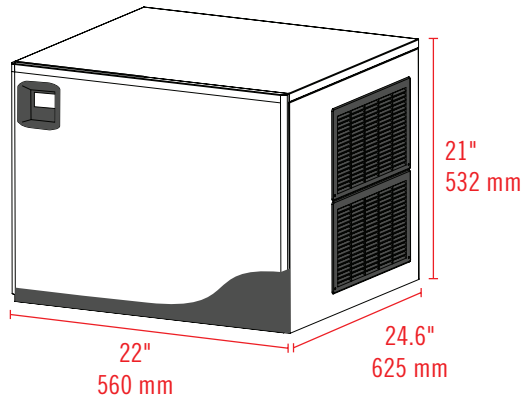

FULL DICE CUBE (N MODELS)

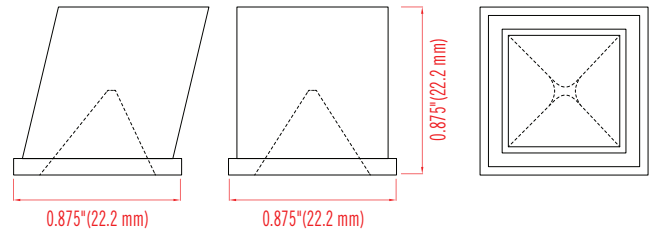

HALF DICE CUBE (NH MODELS)

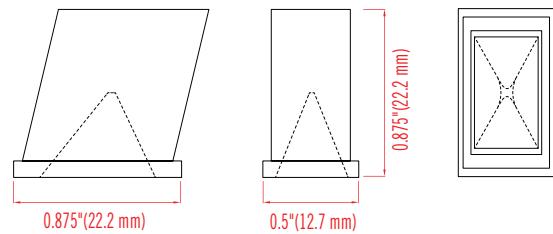

MODEL	EXTERNAL DIMENSIONS	DAILY ICE PRODUCTION (70°F Air / 50°F Water)	COMPATIBLE MAXX ICE STORAGE BIN	NET WEIGHT / SHIPPING WEIGHT	AMP DRAW (MAKING / HARVESTING)	REFRIGERANT AND CHARGE SIZE	ELECTRICAL
MIM360N	22" x 24.6" x 21" (560 x 625 x 532 mm)	373 lbs (169 kg)	MIB310N	93 lbs (42 kg) 111.5 lbs (50.5 kg)	7.5A / 10.5A	R-404a 24.5oz (695g)	115V / 60Hz / 1Ph
MIM360NH	22" x 24.6" x 21" (560 x 625 x 532 mm)	361 lbs (164 kg)	MIB310N	93 lbs (42 kg) 111.5 lbs (50.5 kg)	7.5A / 10.5A	R-404a 24.5oz (695g)	115V / 60Hz / 1Ph

INSTALLATION

- A clearance of 2" from the wall is recommended to promote adequate cooling air circulation
- A gravity drain line is required to install this ice machine
- For optimal performance, the use of a water filter is recommended